

## CHAPTER 12

# CRASH RESCUE AND FIRE FIGHTING

### INTRODUCTION

Fire fighting is a highly technical profession. Fire fighting in and around crashed aircraft is a highly specialized field of fire fighting. An individual willing to become a fire fighter must possess the following qualities: alertness, courage, dedication, agility, physical strength, and the ability to be an exacting team worker.

The primary duty of the fire fighter is saving life. If there is a fire aboard an aircraft with ordnance on board, there is potential for loss of life. If an ordnance cook-off occurred, the top priority would be to cool off the ordnance, simultaneously lay a personnel rescue path, and to extinguish the fire.

During frequent drills and training sessions, it is important for you to actually use all equipment, extinguishing agents, and tools so you will learn their capabilities and limitations.

### THE CHEMISTRY OF FIRE

**LEARNING OBJECTIVE:** Identify the four elements necessary to produce fire, and recognize the characteristics associated with the different classes of fires. Recognize the characteristics of the five different extinguishing agents.

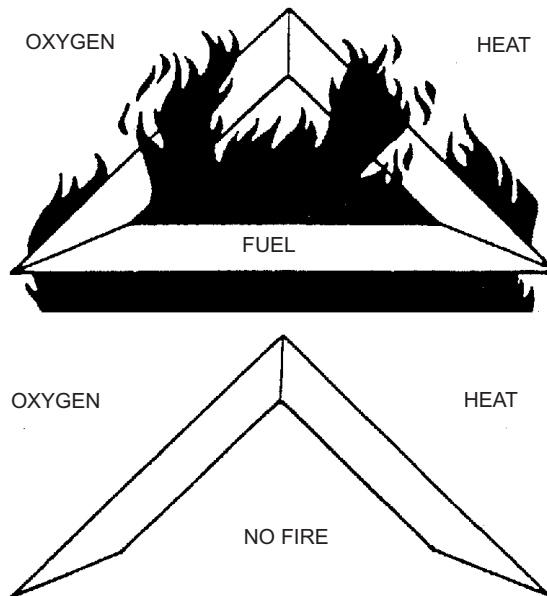

Anf1201

Figure 12-1.—Requirements for combustion.

Fire is the most common form of chemical reaction. The process of fire may be regarded as a chemical triangle (fig. 12-1). The three sides consist of fuel (combustible matter), heat, and oxygen. After extensive research, the presence of a fourth element has been identified. It is the chemical chain reaction (fig. 12-2) that takes place in a fire that allows the fire to

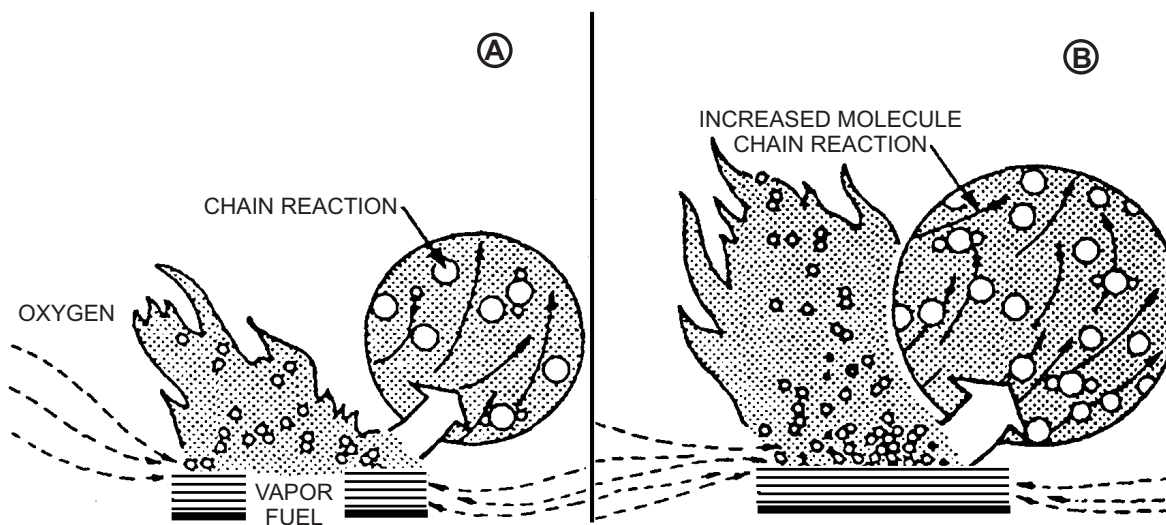

ANf1202

Figure 12-2.—Chain reaction.

both sustain itself and grow. This process of fire is now called the "fire tetrahedron." See figure 12-3.

The most common method of controlling or extinguishing a fire is to eliminate one or more of sides of the tetrahedron. This can be accomplished by the following methods.

1. Smothering—removing the oxygen
2. Cooling—removing the heat
3. Starving—removing the fuel or combustible matter

There are two terms you need to understand about fires. These are the *fire point* and the *flash point*.

The *fire point* of a substance is the lowest temperature at which its vapors can be ignited and will continue to burn. At this temperature, the vapor will ignite spontaneously in the air. Also, substances don't have to be heated to this ignition temperature throughout in order to ignite.

The *flash point* of a substance is the temperature at which the substance gives off enough vapors to form an ignitable mixture with the air near the substance's surface. An ignitable mixture is a mixture within the explosive range. The mixture is capable of spreading a flame away from the source of ignition when ignited. For example, fuel will spontaneously ignite when a portion of it (or its vapors) is exposed to temperatures around 500°F (ignition temperature). It is capable of

being touched off by a match or spark at temperatures down to -5°F (fire point). It will also flash across the surface at temperatures from -5°F down to -45°F (flash point). From these examples, you can readily see that fuel has a low flash point and is easily ignited. Fuel is a constant fire hazard around aircraft. A spark, heat caused by friction, or an electrical discharge could supply enough heat to cause fuel to flash.

## CLASSES OF FIRE

Different types of fires are combated by different means. It is important that you know how to identify the various types of fires and understand why each type must be combated in a specific way.

### Class A

Class A fires occur in combustible materials, such as bedding, mattresses, books, cloth, and any matter that produces an ash. All fires of this class leave embers, which are likely to rekindle if air comes in contact with them. Class A fires must not be considered extinguished until the entire mass has been cooled below its ignition temperature. Smothering (removing the oxygen) is not effective for class A fires because it does not lower the temperature of the smoldering embers below the surface. The extinguishing agents most effective for class A fires are solid water stream, both high- and low-velocity fog, CO<sub>2</sub>, and water immersion.

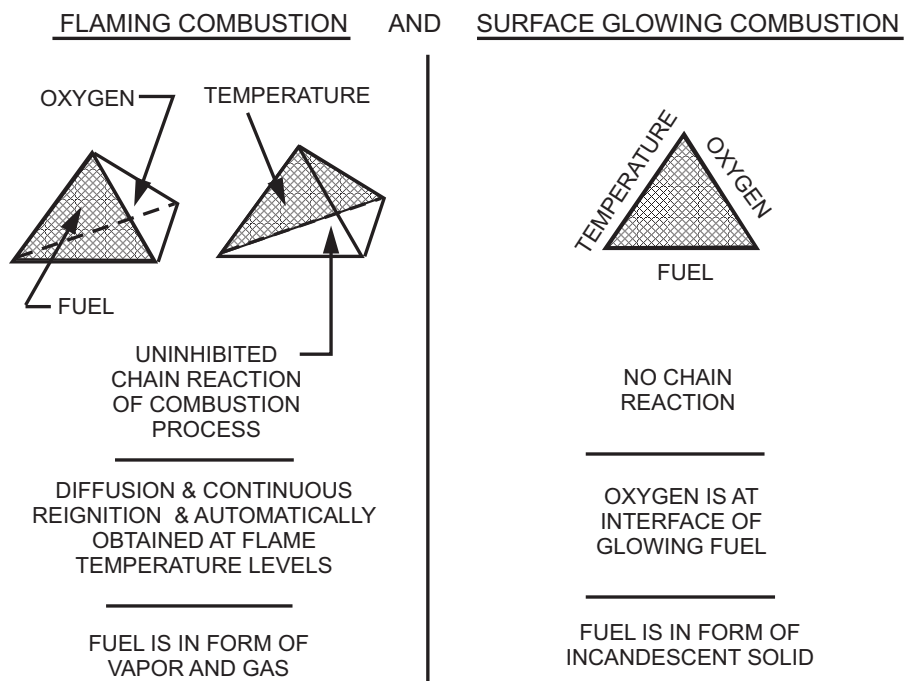

Anf1203

Figure 12-3.—Tetrahedron and fire triangle.

## Class B

Class B fires occur with flammable liquid substances. Examples of class B fires are gasoline, jet fuels, paints, grease, and any petroleum-based product. These and other combustible substances do not leave embers or ashes. Class B fires are extinguished by providing a barrier between the burning substance and oxygen necessary for combustion. Chemical and mechanical foams produce such a barrier and are known as permanent smothering agents, but their effect is only temporary. The application must be renewed if there is any danger of reignition. The extinguishing agents recommended for combating class B fires are CO<sub>2</sub>, PKP, Halon, and Aqueous Film-Forming Foam (AFFF).

**NOTE:** Water by itself is **NOT** recommended for use on class B fires.

## Class C

Class C fires are energized electrical fires that are attacked at prescribed distances by using nonconductive agents such as CO<sub>2</sub> and Halon 1211. The most effective tactic is to de-energize the system and handle the fire as a class A fire. When fires are not deep seated, clean agents that pose no cleanup problem, such as Halon 1211 or CO<sub>2</sub>, are the preferred extinguishing agents.

### WARNING

Water in any form, particularly salt water, is dangerous when used on electrical equipment.

## Class D

Class D fires are combustible metals, such as magnesium and titanium. Water in large quantities, as high velocity fog, is the recommended extinguishing agent. When water is applied to burning class D materials, there may be small explosions. The fire fighter should apply water from a safe distance or from behind shelter. Metal fires on board ships are commonly associated with aircraft wheel structures.

## EXTINGUISHING AGENTS

There are many materials that may be used as fire-fighting agents. The primary agents discussed in the following paragraphs are the most extensively used aboard naval ships.

## Water

Water is a cooling agent, and on board ship, the sea provides an inexhaustible supply. If the surface temperature of a fire can be lowered below the fuel's ignition temperature, the fire will be extinguished. Water is most efficient when it absorbs enough heat to raise its temperature to 212°F (100°C) or boiling point. At this temperature, the seawater will absorb still more heat until it changes to steam. The steam carries away the heat, which cools the surface temperature.

Water in the form of fog is very effective for fire-fighting purposes. Additionally, water fog can provide protection to fire fighters from heat. However, the fog must be applied directly to the area to be cooled if its benefits are to be realized.

Water in the form of a straight stream (also called solid stream) is used to reach into smoke-filled spaces or areas at a distance from the fire fighter. When a straight stream is needed as an extinguishing agent, it should be directed into the seat of the fire. For maximum cooling, the water must come in direct contact with the burning material. A straight stream is best used to break up and penetrate materials.

## Aqueous Film-Forming Foam (AFFF)

AFFF is composed of synthetically produced materials similar to liquid detergents. These film-forming agents are capable of forming water solution films on the surface of flammable liquids. AFFF concentrate is nontoxic and biodegradable in diluted form. When proportioned with water, AFFF provides three fire-extinguishing advantages.

1. An aqueous film is formed on the surface of the fuel that prevents the escape of the fuel vapors.
2. The layer effectively excludes oxygen from the fuel surface.
3. The water content of the foam provides a cooling effect.

The primary use of AFFF is to extinguish burning flammable or combustible liquid spill fires (class B). AFFF has excellent penetrating characteristics and is superior to water in extinguishing class A fires.

## Carbon Dioxide (CO<sub>2</sub>)

CO<sub>2</sub> is an inert gas and extinguishes fires by smothering them. CO<sub>2</sub> is about 1.5 times heavier than air, which makes it a suitable extinguishing agent

because it tends to settle and blanket the fire. CO<sub>2</sub> is a dry, noncorrosive gas, which is inert when in contact with most substances and will not leave a residue and damage machinery or electrical equipment. CO<sub>2</sub> is a nonconductor of electricity regardless of voltage, and can be safely used in fighting fires that would present the hazard of electric shock.

CO<sub>2</sub> extinguishes the fire by diluting and displacing its oxygen supply. If gaseous CO<sub>2</sub> is directed into a fire so that sufficient oxygen to support combustion is no longer available, the flames will die out. CO<sub>2</sub> has limited cooling capabilities, and may not cool the fuel below its ignition temperature. It is more likely than other extinguishing agents to allow reflash. Therefore, the fire fighter must remember to stand by with additional backup extinguishers.

**NOTE:** CO<sub>2</sub> is not an effective extinguishing agent for fires in materials that produce their own oxygen supply, such as aircraft parachute flares or fires involving reactive metals, such as magnesium and titanium.

### **Halon 1211**

Halon is a halogenated hydrocarbon. Halon 1211, known chemically as *bromochlorodifluoromethane*, is colorless and has a sweet smell. Halon attacks the fire by inhibiting the chemical chain reaction. Halon decomposes upon contact with flames or hot surfaces above 900°F (482°C).

Halon 1211 is used for twin agent (AFFF/Halon 1211) applications on board flight and hangar deck mobile fire-fighting equipment. For flight and hangar deck fire-fighting procedures, you should refer to NAVAIR 00-80R-14, *NATOPS U.S. Navy Aircraft Fire-Fighting and Rescue Manual*.

### **Potassium Bicarbonate (Purple-K-Powder or PKP)**

Potassium bicarbonate (PKP) is a dry chemical principally used as a fire-fighting agent for flammable liquid fires. When PKP is applied to fire, the dry chemical extinguishes the flame by breaking the combustion chain. PKP does not have cooling capabilities on fire. PKP is highly effective in extinguishing flammable liquid (class B) fires. Although PKP can be used on electrical (class C) fires, it will leave a residue that may be hard to clean. Also, when combined with moisture, it may corrode or stain the surfaces it settles on.

PKP does not produce a lasting inert atmosphere above the surface of a flammable liquid. Therefore, its use will not result in permanent extinguishing if ignition sources, such as hot metal surfaces or persistent electrical arcing, are present. Reflash of the fire will most likely occur. The ingredients used in PKP are nontoxic. However, the discharge of large quantities may cause temporary breathing difficulty and, immediately after the discharge, it may seriously interfere with visibility.

*Q12-1. What are the four elements necessary to produce fire?*

*Q12-2. What is the "fire point" of a substance?*

*Q12-3. What is the "flash point" of a substance?*

*Q12-4. What are the four classes of fire?*

*Q12-5. What are the primary fire-extinguishing agents used aboard naval ships?*

## **FIRE-FIGHTING EQUIPMENT**

**LEARNING OBJECTIVE:** Recognize the various systems and equipment used for aircraft fire-fighting on board ships and shore activities.

In assisting the crash fire fighters, you will use very specialized equipment. A crash crew must bring its equipment into action with every pump nozzle delivering at its maximum capacity. Fire-fighting equipment is discussed in the following text.

## **FIREMAIN SYSTEM**

You must get acquainted with the firemain system throughout your ship. You should know the location of the firemain and the riser piping that carries water to the upper decks. You must be able to identify the plugs where hoses can be attached to the mains. You must know the location of all pumps, valves, and controls in the vicinity of your duty and berthing stations.

Fireplugs have outlets either 1 1/2 or 2 1/2 inches in diameter. Some plugs are equipped with wye gates that provide two outlets, each are 1 1/2 inches in size. In some cases, a reducing connection is used so that a 1 1/2-inch hose can be attached to a 2 1/2-inch outlet.

Connected to the fireplugs and stored in adjacent racks are two lengths of either 1 1/2- or 2 1/2-inch diameter hose. The 1 1/2-inch hose is used on smaller ships and below decks on larger ships. This hose is made up in 50-foot lengths, with the necessary end

couplings. All threaded parts of fire hose fittings and couplings have standard threads and are easy to connect. Hoses and fittings 1 1/2 inches and below have standard pipe threads. Those 2 1/2 inches and over have standard Navy hose threads.

Two people working together can quickly prepare a fire hose. You can do the job alone if you place the hose on the deck and hold it down with your foot just behind the fitting. The pressure of your foot will cause the metal fitting on the end of the hose to point upward. In this position you can screw in the nozzle or other fitting.

Fire hose is usually located on a bulkhead rack near a fireplug. Nozzles, extensions called applicators, and spanner wrenches are stowed on the bulkhead near the hose. See figure 12-4. When two lines are located separately on the bulkhead, one is connected to the firemain and the other is left unconnected.

### HIGH-CAPACITY AFFF SYSTEMS

An AFFF station consists of a 600-gallon AFFF concentrate tank, a single-speed injection pump or a two-speed AFFF pump, electrical controllers, valves, and necessary piping. Saltwater and AFFF flow is controlled by hydraulically operated valves, which are actuated by solenoid-operated pilot valves (SOPVs). The SOPVs are activated by electrical switches at user

locations (Pri-Fly, NAVBRIDGE, hose stations, and CON-FLAG stations).

The injection pump system supplies the flush deck nozzles on the flight deck, and the deck edge nozzles on CVNs and some CVs. The two-speed pump operates at 27 or 65 gpm, depending upon the demand. The low-rate output will supply handlines and small sprinkler systems. High-demand systems, such as hangar bay sprinklers, are served by the high-speed output. On selected CVs, the two-speed pump supplies the deck edge nozzles.

### Hangar Deck AFFF Sprinkler System

The AFFF sprinkler systems are installed in the overhead of the hangar deck. The sprinkler system is divided into groups that can be individually actuated. Each group is supplied from two risers—one from a port AFFF injection station and one from a starboard AFFF injection station. Controls to start and stop flow to individual sprinkler groups are located in the conflagration (CONFLAG) stations and along each side of the hangar deck near the related sprinkler group.

### Flight Deck AFFF Extinguishing System

Flight decks have an AFFF fire-fighting system that consists of flush-deck, flush-deck cannon-type, and deck-edge nozzles installed in combination with the

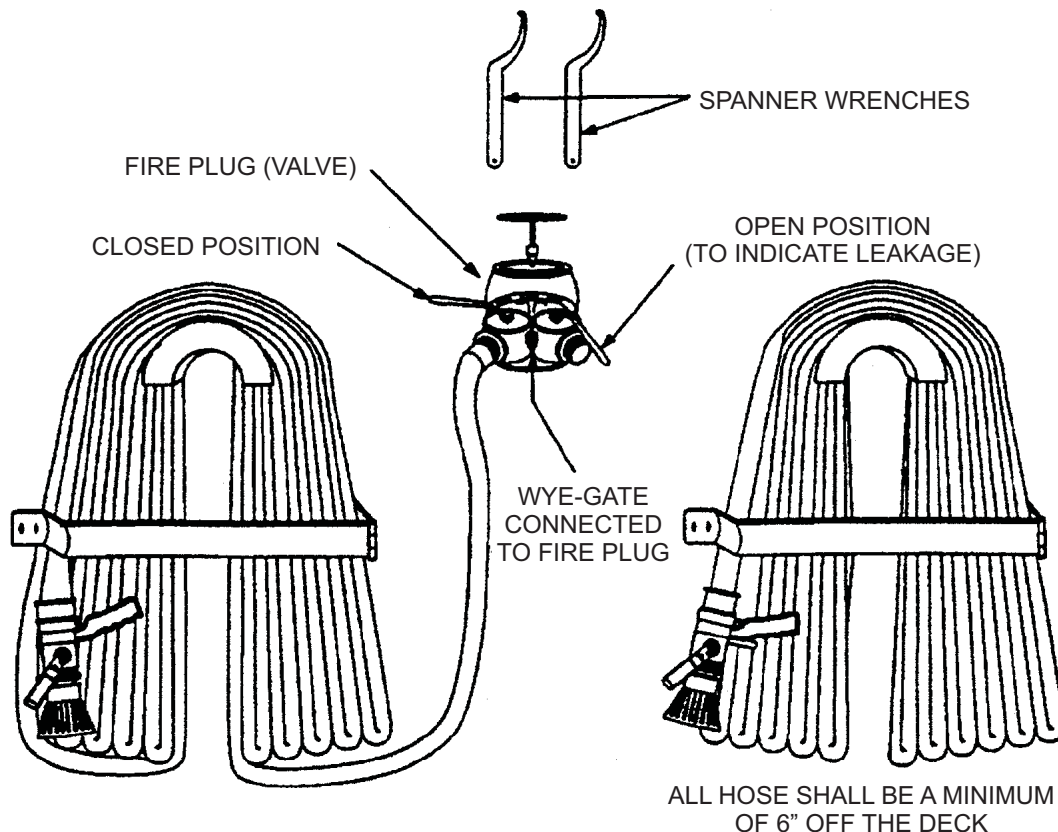

ANF1204

Figure 12-4.—Typical fire hose station.

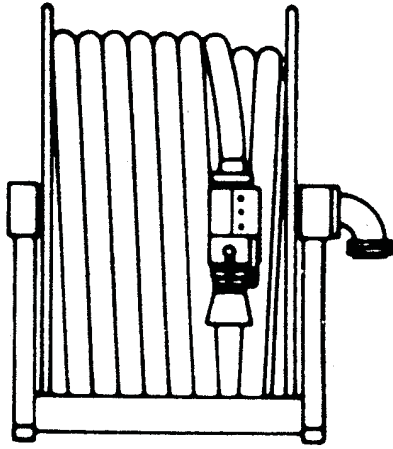

Anf1205

Figure 12-5.—AFFF hose reel.

saltwater washdown system. AFFF from the concentrate tank is injected into the saltwater (injection point is on the 03 level just downstream of the saltwater control valve) via a positive displacement pump, usually 60 gpm. This injection pump serves the flush-deck and cannon-type nozzles. Deck edge nozzles may be served by the AFFF two-speed pump system or single-speed injection pump system.

Controls for the flight deck fixed fire-extinguishing system are located in both Pri-Fly and on the navigation bridge. The controls allow for selection of saltwater AFFF or system shutdown.

### AFFF Hose Reel Station

Hangar bay AFFF hose outlets are located port and starboard near the AFFF injection stations from which they are supplied. A push-button control is located

adjacent to each AFFF hose station. The station has a 1 1/2-inch hose reel and one 2 1/2-inch hose outlet (fig. 12-5).

Flight deck AFFF hose outlets are located in catwalks and near the island. The station has one reel of 1 1/2-inch hose and/or one 2 1/2-inch hose outlet or two 2 1/2-inch hose outlets with hose and nozzle preconnected to each outlet. A push-button control, X50J phone circuit box, and E call button are located next to each AFFF hose station. There is emergency lighting at each hose reel station. The controls are located in Pri-Fly and on the NAVBRIDGE.

## PORTABLE FIRE-FIGHTING EQUIPMENT

As you become more familiar with aircraft fire-fighting tactics and equipment, you will become more familiar with the many different types of portable equipment that the fire fighter uses to combat and contain aircraft fires. Some of the equipment you will use is discussed in this section.

### Vari-Nozzles

Vari-nozzles are used on all AFFF and saltwater hose lines. Flow rates are 250 gpm for all 2 1/2-inch hose lines. Nozzles on 1 1/2-inch AFFF hoses on flight and hangar decks are the 125 gpm units. Nozzles on the 1 1/2-inch saltwater lines and those used with AFFF in-line inductors are 95 gpm models. All nozzle gpm flow rates are based on 100 psi pressure at the nozzle inlet. See figure 12-6.

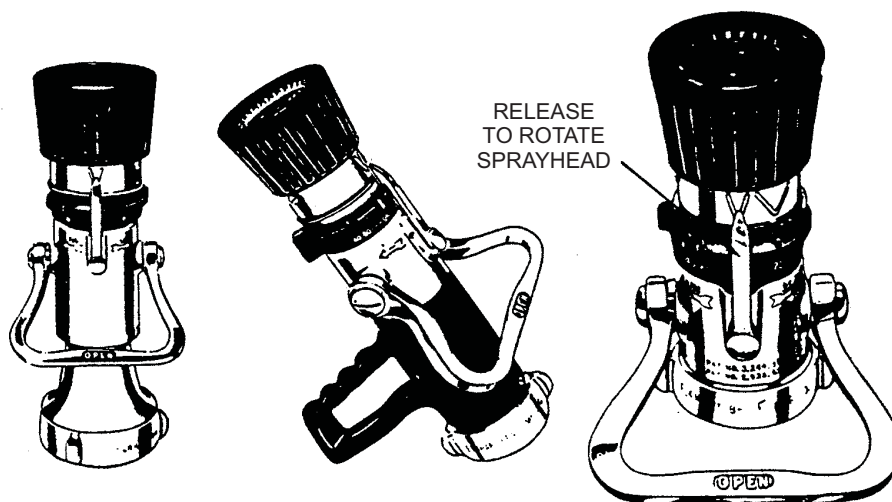

Anf1206

Figure 12-6.—Examples of variable-stream fog nozzles.

## Hoses

The standard Navy fire hose is a double jacketed, synthetic fiber with a rubber or similar elastomeric lining. The outer jacket is impregnated to increase wear resistance. The impregnating material contains an orange colored pigmentation for easy identification. Navy fire hose comes in 50-foot lengths and has a maximum operating pressure of 270 psi. Optimum hose handling occurs between 90 and 150 psi. Pressure above 150 psi is hazardous because excessive nozzle reaction force may result in loss of nozzle control.

Noncollapsible rubber hose for the AFFF hose reel system is available in 3/4-inch and 1 1/2 inch size. The length of these hoses varies in size depending upon application and location.

## Tools

A fire fighter's tool kit should contain the following tools.

- Large claw tool; small claw tool
- Crowbar
- Parachute knife
- Pliers; screwdriver
- Wrench
- Hacksaw; metal saw
- Chisels
- Flashlight
- Carpenter's hammer; maul
- Bolt cutters
- Notched ax

NAVAIRSYSCOM developed what is called an aircraft tool kit (fig. 12-7) for crash trucks. The station fire chief must ensure that one of these kits is carried on

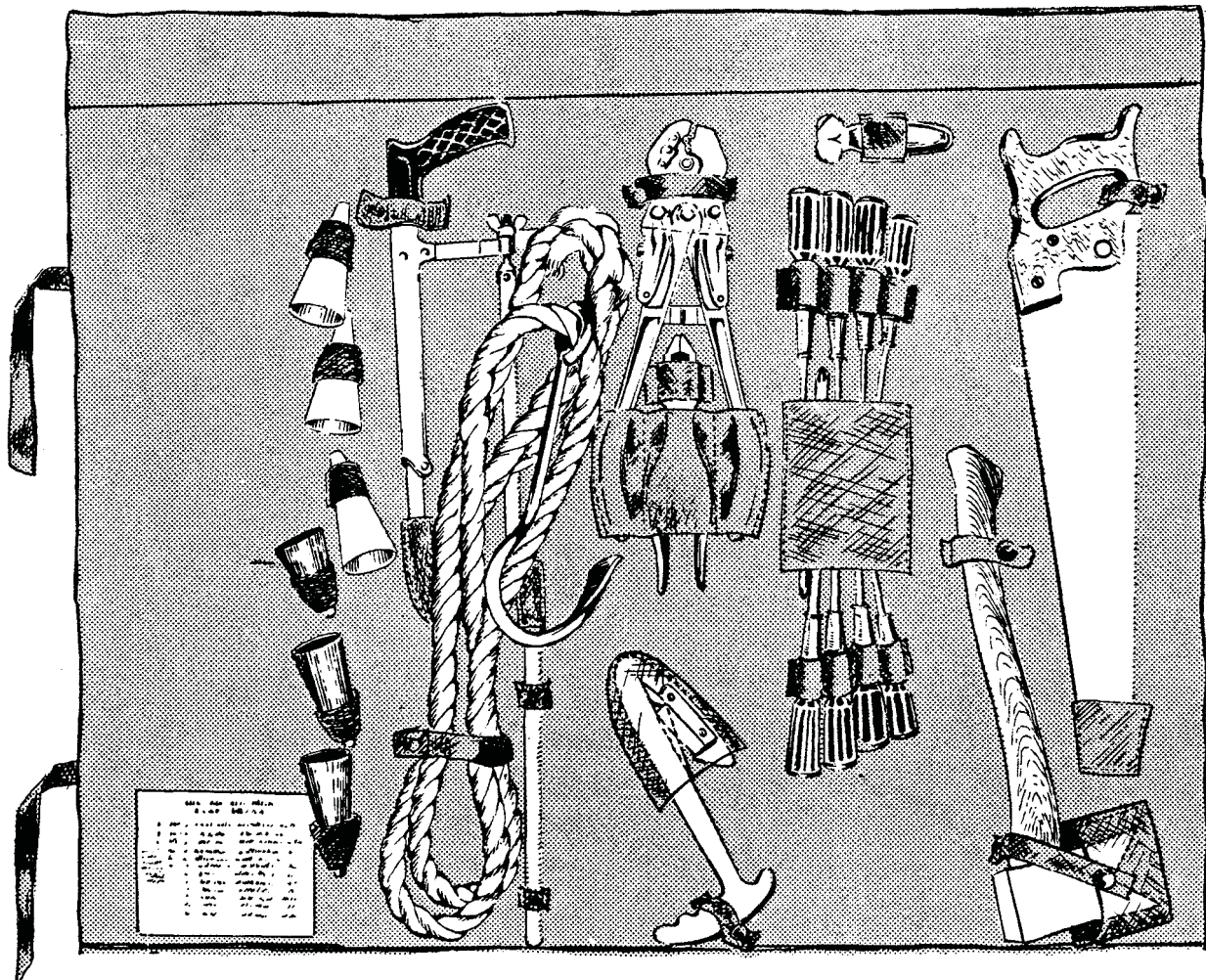

Figure 12-7.—Crash rescue tool kit.

Anf1207

each of the crash trucks assigned to the fire-fighting crew. The kit consists of a canvas tool roll with pockets or holders for specified tools. The crash kit contains tools for forced entry. Fire fighters use these tools in rescuing occupants trapped in aircraft. The kit contains three tapered, hard-rubber plugs and three hardwood plugs. These plugs are used to stop fuel tank leaks.

## PROTECTIVE CLOTHING

Aircraft fire-fighting/rescue protective clothing is a prime safety consideration for personnel engaged in fire-fighting and rescue work. Aluminized protective clothing offers a means of providing protection to fire fighters because of its high percentage of reflectivity to radiant heat. Aluminized proximity fabrics have been adopted for use in the Navy Mishap/Rescue Program. It is important to point out that these garments are not classified as entry suits, but are known as proximity clothing to be worn with fire fighter's knee-length boots that have safety toes and soles.

### Care and Maintenance of Protective Clothing

The heat-reflective ability of aluminized clothing is reduced when the clothing is stained or otherwise soiled. Therefore, you **must** give careful attention the care and maintenance instructions for protective clothing. Some guidelines are as follows:

1. Store clothing on hangers, with suitable hanging space to prevent aluminized fabrics from creasing or cracking. If the garment is folded, the folds should be loose. Do not sit on a folded garment.
2. Sponge off dirt and soot by using mild soap and water. Dry aluminum surfaces with a clean cloth. Rub gently to avoid removal of the aluminum.
3. Remove grease stains by using dry-cleaning solvents. (**NOTE:** Isopropanol or perchloroethylene will react with the metal in proximity suits and may etch the aluminum surface.) Clean the clothing with water and wipe dry. Allow the garment to hang in a ventilated location at room temperature.
4. Remove AFFF by sponging the clothing clean with mild soap and water. Hang the garment to dry in the open or in a place with good circulation. During fire-fighting operations, it is not always possible to prevent fire-fighting agents from getting on protective clothing. However, aluminized protective clothing that has been covered or spotted with agents will have less heat-reflecting ability than the suit normally would provide.

5. Corrosive chemicals will react with the aluminum surface and may etch the metal. Clean the clothing with water and wipe it dry. Allow it to hang in a ventilated location at room temperature.

6. Replace garments when the aluminum wears off or when the fabric cracks or tears. Spraying worn clothing with aluminum serves no useful purpose and is a dangerous practice.

### Care of Facepiece

The gold-coated facepiece is a heat-reflective shield. The facepiece is NOT a sun shield. This item should be kept in excellent condition to maintain the radiant-heat-reflective efficiency. When the gold surface of the facepiece becomes worn, scratched, or marred, 90 percent of the heat protection is lost, and you should immediately replace the facepiece. Other precautions you should take with facepieces are as follows:

1. Keep the protective cover in place when you are carrying or storing the hood to minimize damage to the gold-coated surface. Remove it when using the hood.
2. For adequate protection, replace a worn gold-coated facepiece. When wearing the facepiece, make sure the gold surface is on the outside as marked on the edge.
3. Avoid touching or wiping the gold surface as much as possible.
4. Clean the facepiece, without removing it from the hood, by using a clean, soft cloth with mild soapy water, and then rinse and pat dry.

*Q12-6. What size diameter are the fireplug outlets aboard ship?*

*Q12-7. Where is the AFFF sprinkler system installed on the hangar deck?*

*Q12-8. What length is a standard Navy fire hose?*

*Q12-9. What type of protective clothing offers protection to fire fighters because of its high percentage of reflectivity to radiant heat?*

## AIRCRAFT FIRE-FIGHTING AND RESCUE VEHICLES

**LEARNING OBJECTIVE:** Recognize the types of fire-fighting and rescue vehicles used aboard ship.

The Navy uses different types of trucks. The use depends on the base, type of aircraft assigned, and anticipated types of fires. Some of the trucks used by the Navy are the Oshkosh T-3000, the P-4A vehicle, the P-19 fire-fighting truck, and the P-25 shipboard fire-fighting truck. Shore-based Twinned Agent Units (TAUs) and Shipboard Twinned Agent Units (SBTAUs) are also used.

### OSHKOSH T-3000

The Oshkosh T-3000 (fig.12-8) is a diesel-powered, six-wheeled-drive truck with an automatic transmission. The operator controls consist of power-assisted steering, air or mechanical brakes, transmission range selector, and in-cab controls for operating the fire-fighting system. The water storage tank has a capacity of 3,000 gallons; the AFFF concentrate tank holds 420 gallons. The roof turret has a discharge rate of 600 to 1,200 gpm and an infinitely variable pattern from straight stream to fully dispersed. The bumper turret is electric joystick controlled with auto-oscillation. The discharge rate is 300 gpm and it is also variable pattern. Two 15-foot, 1 3/4-inch preconnected handlines are provided, one per side. The

handlines have a discharge rate of 95 gpm and have a pistol grip with variable pattern.

### P-4A VEHICLE

The P-4A vehicle (fig. 12-9) is diesel powered with an optional all-wheel drive. It has a six-speed, semiautomatic, power shift transmission. The operator's controls has power-assisted steering, air-over-hydraulic power boost brakes, transmission range selector, and in-cab controls for operating the vehicle's fire-fighting systems.

The water storage tank has a capacity of 1,500 gallons. The AFFF concentrate pumps (centrifugal) are powered by the truck engine by means of power dividers. The concentrate and water are carried to each of the discharge points in separate lines and are mixed in venturi inductors before discharge. The P-4A is provided with a manually maneuvered, 750-gpm constant-flow, variable-stream roof turret.

The P-4A is also provided with a 250-gpm bumper turret mounted in front of the cab and controlled hydraulically from within the cab. The handline is mounted in front center of the vehicle in a compartment

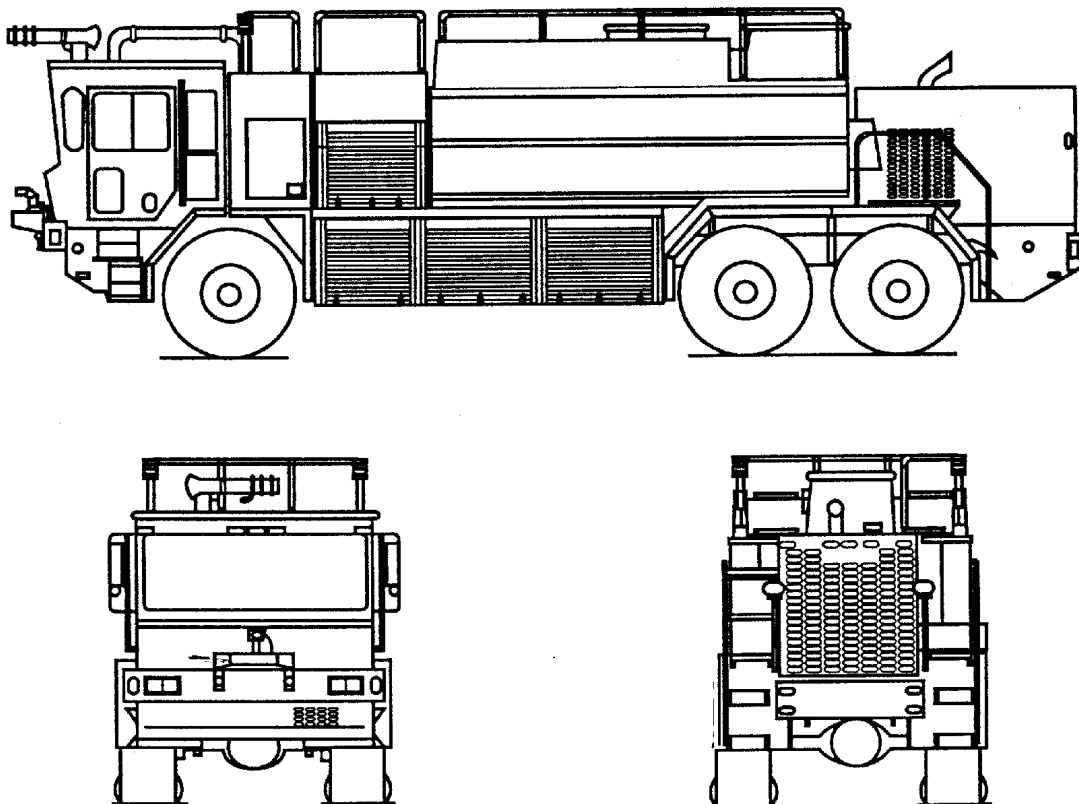
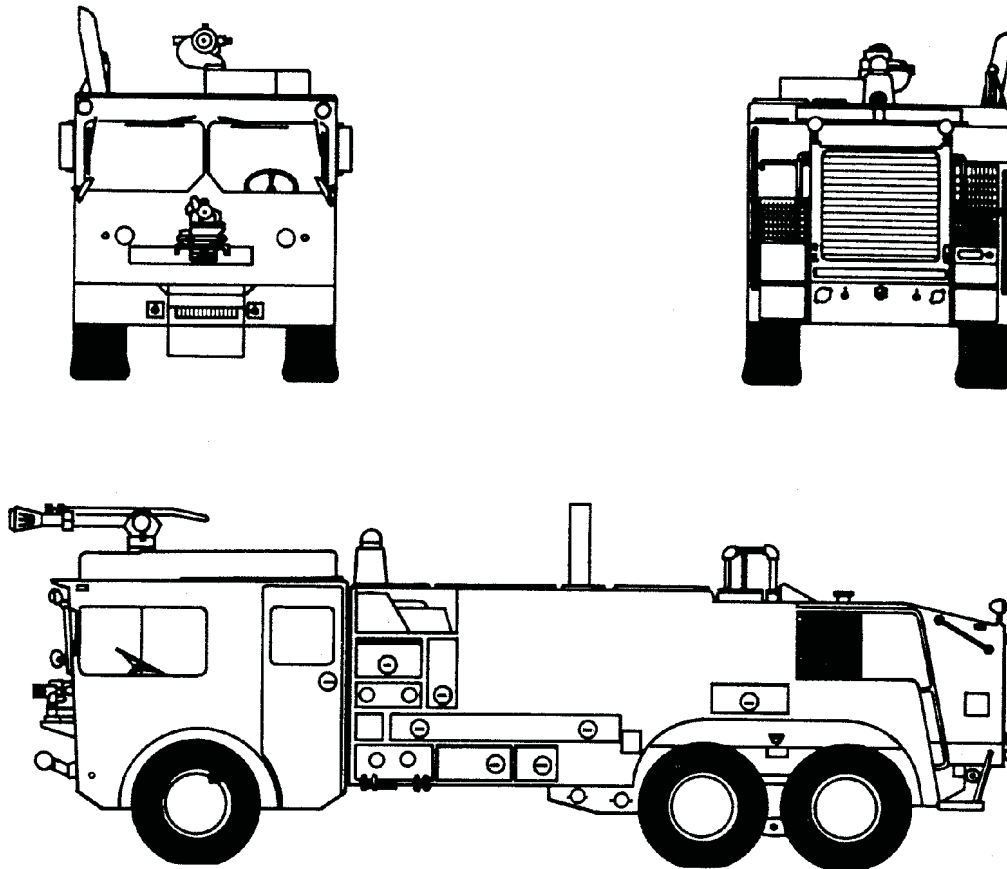

Figure 12-8.—T-3000 aircraft fire-fighting rescue vehicle.

Anf1208



Anf1209

Figure 12-9.—P-4A aircraft fire-fighting and rescue vehicle.

under the cab. The reel is provided with 150 feet of 1 1/4-inch-diameter hose. The handline has a 75 to 100 gpm discharge capacity. An air motor provides for powered rewind. Four 30-pound PKP dry-chemical fire extinguishers are provided with each vehicle. When both the roof turret (750 gpm) and the bumper turret (250 gpm) are operating, the truck depletes its self-contained water supply in 1 1/2 minutes.

### **P-19 FIRE FIGHTING TRUCK**

The P-19 has a diesel-engine-powered, 4 × 4, all-wheel-drive chassis. A single diesel engine powers the truck drive train and water pump. The fire-fighting systems of the truck are self-sufficient. No outside source for extinguishing agents is needed. The truck contains its own pressure pumps and fire-fighting equipment. Water, foam, and Halon 1211 are carried in tanks built into the truck body. The truck body is insulated, which prevents heat loss from the truck's interior during cold weather. The insulation also provides protection from fire heat.

Water or a combination of water and foam can be used to put out a fire. Agents are delivered through the cab-mounted roof turret, the bumper turret, or the handline. These can be used alone or at the same time. The Halon system uses its own handline. The chassis design allows the truck to operate in all kinds of weather and on off-road terrain.

The P-19 has a water capacity of 1,000 gallons, and the foam tank holds 130 gallons. The single-roof turret has a discharge capacity of 500 gpm, and the bumper turret discharges agent at 250 gpm.

AFFF can be applied by using a 100-foot, 1-inch-diameter (60-gpm), reel-mounted handline. Five hundred pounds of Halon 1211 is also available on another 100-foot-long, 1-inch-diameter, reel-mounted handline.

### **A/S32P-25 SHIPBOARD FIRE-FIGHTING VEHICLE**

The P-25 shipboard fire-fighting vehicle (figs. 12-10 and 12-11) is a 4-wheel (2-wheel drive), 6

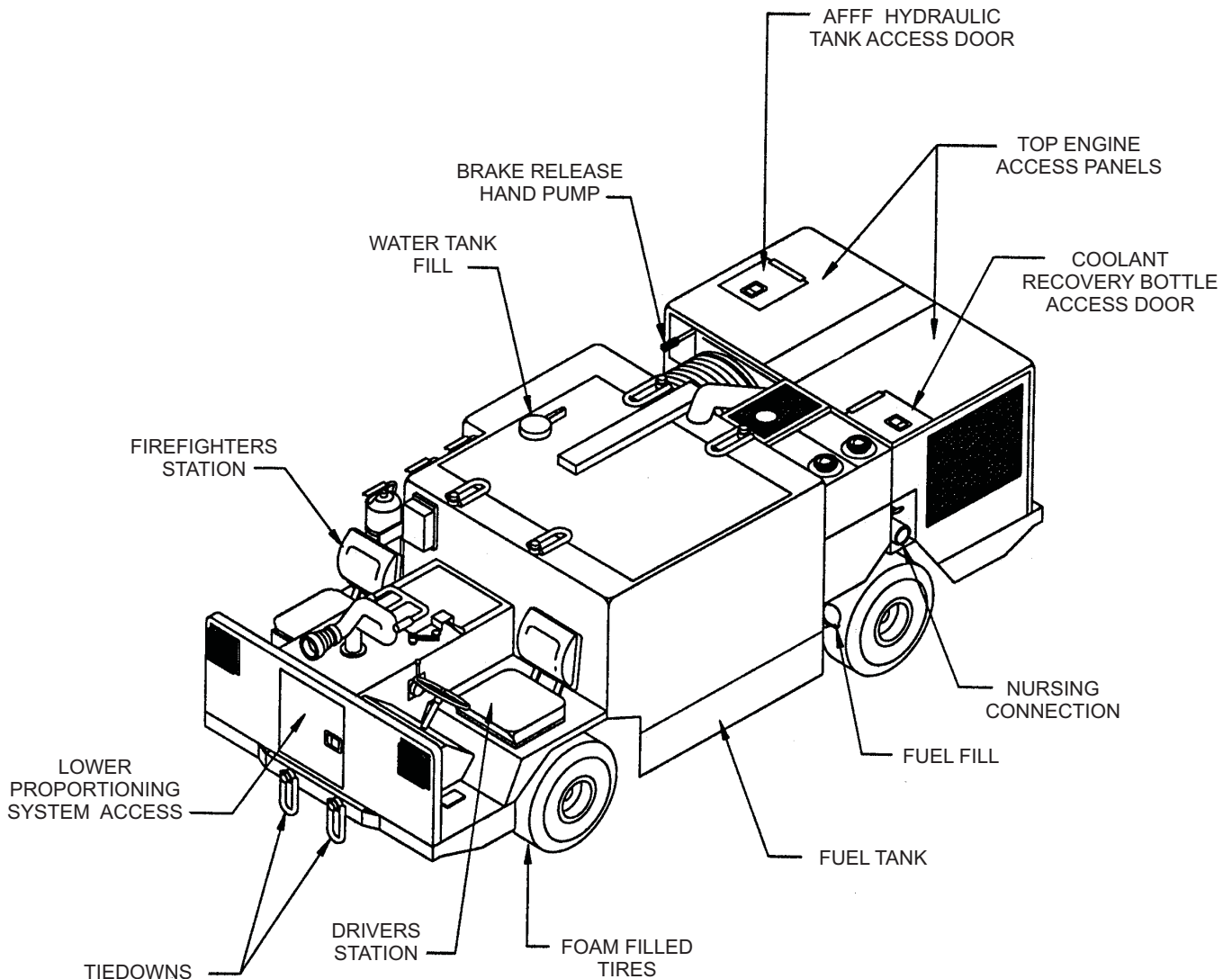

Anf1210

Figure 12-10.—A/S32P-25 shipboard fire-fighting and rescue vehicle—major assemblies and components (left side).

cylinder, turbocharged, liquid cooled, 24-volt, diesel-powered vehicle, with a hydrostatic drive system that transmits power to the rear wheels. Steering is performed by a single hydraulic cylinder and tie rod assembly that controls the front wheels. Dynamic vehicle braking is provided by the hydrostatic drive system. When the accelerator is released, the brakes automatically engage. Separate tanks within the vehicle chassis carry 750 gallons of water and 55 gallons of AFFF (Aqueous Film-Forming Foam). Three 20-pound fire extinguishers containing HALON 1211 (Halogenated Extinguishing Agent) are stored on the right side of the vehicle. One nursing line connection on each side of the vehicle provides AFFF mixture from the ship's system directly to the vehicle's water pump.

The vehicle has seating for a crew of two. The driver compartment is located at the left forward end of the vehicle and contains the main control panel for activating the fire-fighting systems. AFFF can be sprayed from both the forward turret nozzle and handline hose reel nozzle. These nozzles operate independently and can be used simultaneously to make this vehicle ready for fire-fighting duty.

#### TWINNED AGENT UNIT (TAU-2H)

The Twinned Agent Unit (TAU-2H) fire extinguisher is a dual-agent apparatus that is designed primarily for extinguishing class B fires, and it is employed aboard ship and at shore facilities. The TAU-2H is normally located at hot refueling sites, or it

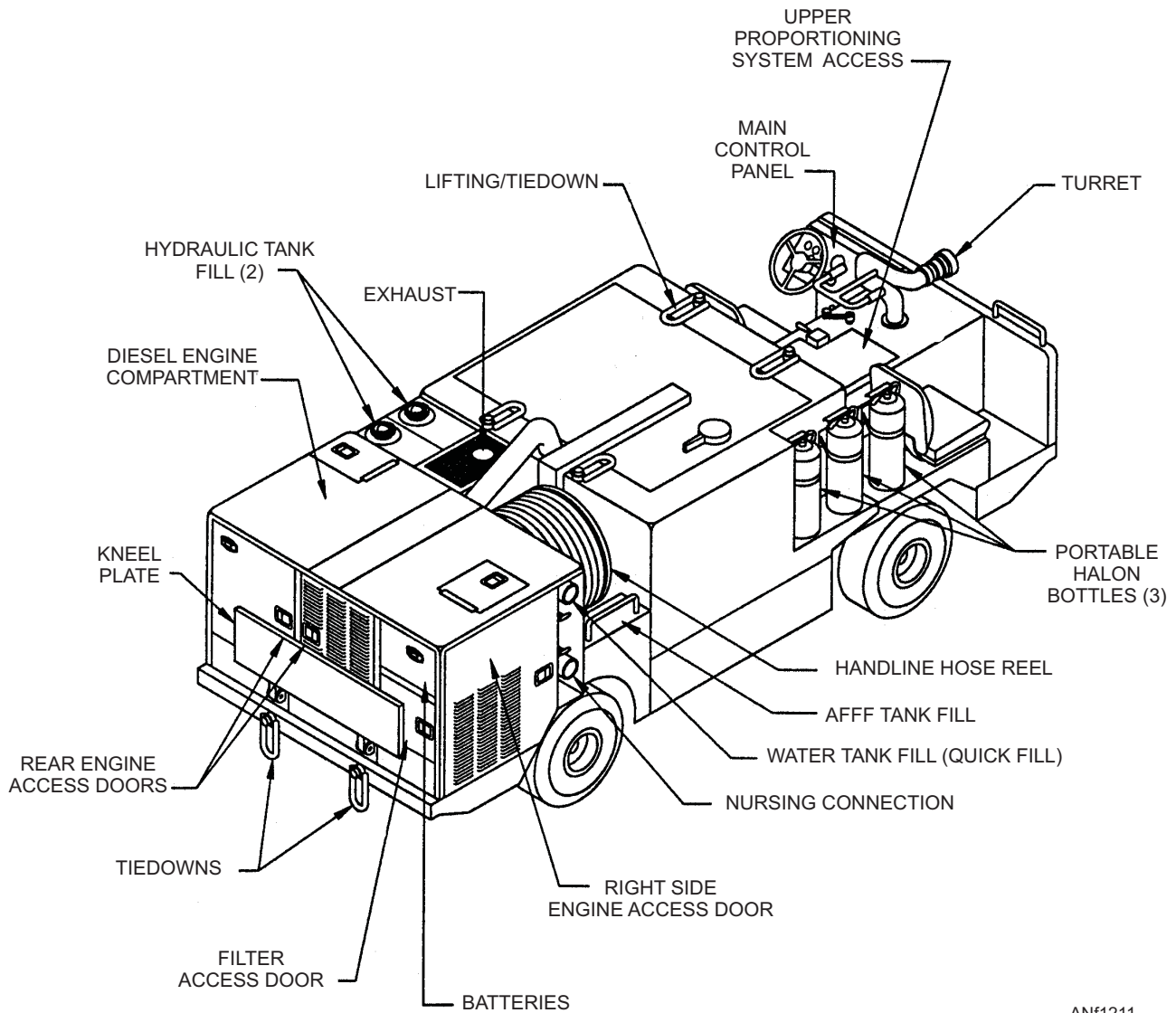

ANf1211

Figure 12-11.—A/S32P-25 shipboard fire-fighting and rescue vehicle—major assemblies and components (right side).

can be vehicle-mounted. The TAU-2H is a self-contained unit with two agent tanks—one containing 86 gallons of AFFF premixed solution and the other containing 200 pounds of Halon 1211. The system permits use of the fire-fighting agents either separately or simultaneously.

The TAU-2H (fig. 12-12) employs a noncollapsible dual hose line encased in a fire-resistant cotton jacket. The hose line is normally mounted on a reel. The fire-extinguishing agents are propelled by nitrogen supplied from two pressurized cylinders, which are mounted on the framework. The twinned nozzles on the handline expel the fire-fighting agents. The Halon nozzle is equipped with a low-reaction discharge tip. The AFFF nozzle is equipped with a aspirating tip. Duel pistol grip handles and triggers operate the shutoff valves. Extinguishment is obtained by applying agents

in a sweeping motion, using the chemical agent Halon 1211 to gain initial extinguishment, followed by application of AFFF to blanket the combustible liquid and preclude reignition.

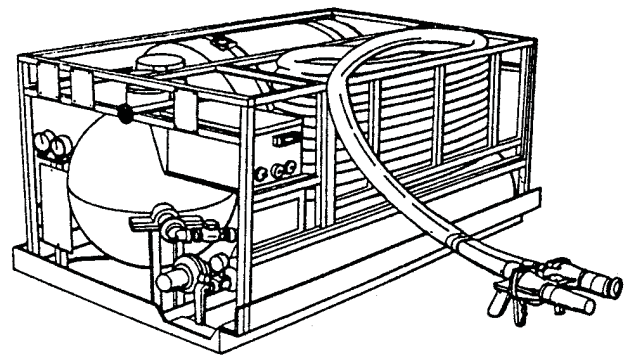

ANf1212

Figure 12-12.—TAU-2H twinned agent unit.

- Q12-10. What type of aircraft fire-fighting rescue vehicles are used at shore-based activities?
- Q12-11. What type of aircraft fire-fighting rescue vehicles are used aboard aircraft carriers?
- Q12-12. What type of fire-fighting agents are contained in the Twinned Agent Unit (TAU-2H)?

## AIRCRAFT FIRE HAZARDS

**LEARNING OBJECTIVE:** Identify the different hazards associated with aircraft fires, and recognize aircraft fluid line identification markings.

Not every crash results in fire. The responsibility of the crash fire fighter does not end when fire fails to occur. Serious actual and potential fire hazards may have been created, which you must eliminate or minimize without delay.

The greater the damage to the aircraft, the greater the possibility of fuel spillage. A spark or a hot engine part could ignite fuel vapors and set off a full-fledged fire. You should take every precaution to guard against accidental ignition. Personal laxity or unfamiliarity with ordinary preventive measures could allow a delayed fire to occur, which could endanger personnel.

## FLAMMABLE, HAZARDOUS, AND FIRE ACCELERATING MATERIALS

Accelerating materials carried on aircraft are of major concern to the aircraft rescue and fire-fighting crews. Aviation gasoline (AVGAS), jet fuels (JP-4, JP-5, and JP-8), engine oils, oxygen systems, and hydraulic fluids constitute problems in aircraft fire-fighting. Some of these fuels have restrictions as to where they can be used; for example, JP-4 is prohibited aboard ship due to its flash point.

### CAUTION

Under aircraft crash impact conditions where fuel-air mixtures or mists are created, all fuels are easily ignited.

## Aviation Gasoline (AVGAS)

The flash point (by closed cup method at sea level) of AVGAS is  $-50^{\circ}\text{F}$  ( $-46^{\circ}\text{C}$ ). The rate of flame spread has also been calculated to be between 700 and 800 feet per minute.

## JP-4 Fuel

JP-4 jet fuel is a blend of gasoline and kerosene and has a flash point from  $-10^{\circ}\text{F}$  ( $-23^{\circ}\text{C}$ ). The rate of flame spread has also been calculated to be between 700 and 800 feet per minute.

## JP-5 Fuel

JP-5 fuel is a kerosene grade with a flash point of  $140^{\circ}\text{F}$  ( $60^{\circ}\text{C}$ ). The rate of flame spread has been calculated to be in the order of 100 feet per minute. The lowest flash point considered safe for use aboard naval vessels is  $140^{\circ}\text{F}$  ( $60^{\circ}\text{C}$ ).

## FUEL TANKS

When an aircraft crashes, the impact usually ruptures the fuel lines and fuel tanks. Ordinarily, all the fuel is not liberated at once. There is a source of fuel that is supplying the fire either from the rupture in the tank or from the loosened and ruptured fuel lines in the accessory section of the engine.

The control of the fire around the fuselage section under these conditions presents a very complex problem. The top portion of the tank is more void of liquid than any other section of the tank. Because of the restraining cushion of the liquid itself, the explosive force will be directed upward instead of downward or on a horizontal plane.

Fuel loads can vary from 30 gallons in small aircraft to approximately 50,000 gallons in large jet aircraft. Fuel tanks are installed in a variety of places within the aircraft structural framework or as a built-in part of the wing. Fuel tanks are often carried under the floor area in the fuselage of helicopters. You should refer to *NATOPS U.S. Navy Aircraft Emergency Rescue Information Manual*, NAVAIR 00-80R-14-1, for the exact location of fuel tanks on a particular aircraft. Upon severe impact these tanks generally rupture and result in fire. Many naval aircraft are provided with external auxiliary fuel tanks located under the wings and fuselages.

The aircraft manufacturers conducted a number of tests on external aircraft fuels tanks in which they were exposed to an enveloping fuel fire. These studies show that there were no deflagrations. The tanks did melt or rupture, releasing fuel onto the decks. The time to fuel tank failure (release of fuel) was dependent on the percent of fuel in the tank and ranged from 28 seconds for a 10-percent load to 3 1/2 minutes for a 100-percent load.

There is so little difference in the heat of combustion of the various aircraft hydrocarbon fuels that the severity after ignition would be of no significance from the "fire safety" point of view. The fire-fighting and control measures are the same for the entire group of aviation hydrocarbon fuels.

## OXYGEN SYSTEMS

Oxygen systems on aircraft can present hazardous conditions to fire fighters during an emergency. Liquid oxygen is a light blue liquid that flows like water and is extremely cold. It boils into gaseous oxygen at -297°F (-147°C) and has an expansion rate of approximately 860 to 1. Liquid oxygen is a strong oxidizer, and although it is nonflammable, it vigorously supports combustion.

## GENERAL HAZARDS

During aircraft fire-fighting operations personnel are constantly in harms way, from the actual fire-fighting operations to the salvage and clean-up operations. All components and material in or on the aircraft are considered hazardous to personnel. The following text discusses a few of the hazards that personnel need to be familiar with.

### Anti-icing Fluids

Anti-icing fluids are usually a mixture of about 85-percent alcohol and 15-percent glycerin. While not as great as other aircraft hazards, you should remember that alcohol used in aircraft anti-icing systems burns with an almost invisible flame. The best method of control is by dilution with water.

### Class A Combustibles

Class A combustibles in aircraft fires are best extinguished with AFFF. When aircraft cockpit and interior finish materials are burned or charred, they produce toxic gases. These gases include carbon monoxide, hydrogen chloride, and hydrogen cyanide. Therefore, it is necessary that fire-fighting and rescue personnel who enter an aircraft during a fire sequence be equipped with a self-contained breathing apparatus.

### Ordnance

Naval aircraft carry a wide variety of ordnance in support of their assigned missions. For more information on the characteristics and cook-off times of

ordnance, refer to chapter 8 of this manual and *NATOPS, U.S. Navy Aircraft Firefighting and Rescue Manual*, NAVAIR 00-80R-14, chapter 2.

## Flare Dispensers

The SUU-44/SUU-25 flare dispensers carry eight Mk 45 or LUU-2 paraflares. When the flares are ejected from the dispenser and the tray separates, they must be considered fully armed. Once the tray separates from the flare, it ignites a fuse on the Mk 45 flare, which will fire within 5 to 30 seconds. The LUU-2 flare uses a simple mechanical timer instead of an explosive fuse. If ignited, the Mk 45 or LUU-2 candle should be extinguished by inserting a water applicator tip into the burning end of the candle, applying low-velocity fog. The flare will normally extinguish in less than 30 seconds. If a fog applicator is not readily available, an alternate method is to have a fully outfitted fire fighter cut the shroud lines, pick up the flare by the cold end, jettison it over the side, or remove it to a clear area if ashore.

## Batteries

Alkaline or nickel-cadmium batteries may get hot from internal shorting or thermal runaway. The overheated battery is hazardous to both aircraft and personnel. When an overheated battery is detected, the crash crew should open the battery compartment, check for the following conditions, and take the action indicated:

1. When flame is present, use available extinguishing agent, such as Halon 1211 or CO<sub>2</sub>.

### WARNING

Halon 1211 or CO<sub>2</sub> is an acceptable fire-extinguishing agent once a fire has developed. CO<sub>2</sub> must not be directed into a battery compartment to effect cooling or to displace explosive gases. Static electricity generated by the discharge of the extinguisher could explode hydrogen or oxygen gases trapped in the battery compartment.

2. When the battery is emitting smoke, fumes, or electrolyte in the absence of flame or fire, make sure the battery switch in the cockpit is in the OFF position. Remove the quick disconnect from the battery and, if possible, move the battery clear of the aircraft. Use water fog to lower the battery temperature.

### WARNING

When approaching a battery that is in a thermal runaway condition, aircraft rescue fire-fighting personnel must work in teams of two and must be attired in full protective clothing, with extinguishing agent available for instant use.

## COMPOSITE MATERIALS

The following text discusses the advantages and disadvantages of using composite materials in aircraft construction.

### WARNING

Inhalation of composite fibers resulting from aircraft fires and/or aircraft material damage may be harmful to personnel. Respiratory protection must be worn when personnel are exposed to these potential hazards.

### Composite Materials Reinforced with Carbon/Graphite Fibers

Composite materials that are reinforced with carbon/graphite fibers provide superior stiffness, a high strength-to-weight ratio, and ease of fabrication. As a result, this material is being used extensively in advanced aircraft, such as the AV-8 *Harrier*, to replace heavier metal components. Unfortunately, carbon or graphite fibers can be released into the atmosphere if their epoxy binder burns. Once free, these small lightweight fibers can be transported up to several miles by air currents and, because of their high electrical conductivity, can damage unprotected electrical/electronic equipment.

Until such time as more information is known, aircraft crash and fire-fighting units must attempt to extinguish fires involving carbon-fiber-reinforced composites as quickly as possible and to provide maximum containment of the aircraft debris. The containment and cleanup function is extremely important and must be treated as a special hazard prevention measure. Accordingly, the practices for extinguishing, containment, and cleanup, as stated in paragraph 6.7 of *NATOPS, U.S. Navy Aircraft Firefighting and Rescue Manual*, NAVAIR 00-80R-14, should be observed when an aircraft crash/fire incident

occurs that involves any aircraft that contain carbon-graphite fiber composites. Any aircraft incident involving fire on these types of aircraft must be considered to have potential contamination hazards until positively identified to the contrary.

### Composite Materials Reinforced with Boron/Tungsten Fibers

Composite materials reinforced with boron fibers also provide superior stiffness, a high strength-to-weight ratio, and ease of fabrication. This material is being used in advanced aircraft, such as the F-14, F-15, and F-16, to replace heavier metal components. Unfortunately, boron fibers can be released if their epoxy binder burns. Boron fibers pose less of a problem to unprotected electrical equipment than carbon or graphite fibers, because boron fibers are much heavier and are less likely to become airborne. Also, boron fibers are much less electrically conductive. However, loose boron fibers are stiff and sharp, and thus pose handling problems. The extinguishing, containment, and cleanup practices for boron fibers are the same as those previously outlined for carbon or graphite fibers.

## AIRCRAFT FIRE AND PERSONNEL HAZARDS

Not every crash results in fire. The responsibility of the crash fire fighter does not end when fire fails to occur. Serious actual and potential fire hazards may have been created, which must be eliminated or minimized without delay.

The greater the damage to the aircraft, the greater the possibility of fuel spillage. A spark or a hot engine part could ignite fuel vapors and set off a full-fledged fire. You must take all precautions to prevent accidental ignition. Personal laxity or unfamiliarity with ordinary preventive measures can cause a delayed fire, which could endanger personnel who would otherwise survive a disaster.

### Engine Accessory Section

The most common source of crash fires is the engine compartment, particularly the accessory section. Take steps to prevent ignition of fuel vapors by hot exhaust stacks and collector rings. CO<sub>2</sub> discharged through the cooling flaps, air scoop, or inspection doors is an effective precaution. CO<sub>2</sub> will cause no damage to the engine or its accessories.

## Fuel Spills

Fuel spills can be caused by ruptured fuel lines. These spills should be swept clear of the aircraft. Use water streams and follow up with a layer of foam to halt vaporization. An aircraft should NEVER be dragged or moved unnecessarily. There is great danger that friction will ignite the fuel.

## Selector Valve

You should know the location of the fuel selector valve on as many types of aircraft as possible. In single-engine aircraft, this valve is usually found on the lower left-hand side of the cockpit. In multiengine aircraft, fuel selector valves for all engines are usually found on one panel. Turn the valve to OFF. It is the primary fuel cutoff valve. The valve is used to select various fuel tanks. In the OFF position, the valve completely separates the source of fuel from the engine.

## Battery Switch

Turn the battery switch to OFF. This is the master electrical switch. It is the source of all power to the aircraft electrical system when the engine(s) are not running. Memorize the location of battery switches so you can turn the power off rapidly in emergencies. Disconnect the battery, if possible, as detonators and electrical recognition devices are connected ahead of the master switch. Turning the switch off will not stop the flow of current to these devices.

## Armament

Turn gun switches to OFF so there is no chance of firing a gun accidentally. This is one of the first actions taken by fire fighters to prevent fire at the crash scene.

## CAUTION

When fighting a fire on an aircraft known to have loaded guns aboard, stay out of the area forward of the guns. If rockets or bombs are in the aircraft, stay clear of them, keep low to the deck, and keep the bombs or rockets cool with water fog or fog foam until they are declared safe.

## Ejection Seat

The ejection seat is not normally a fire hazard if fire is not already present. The ejection seat should be disarmed or made safe by qualified personnel. The greatest danger from an ejection seat comes during rescue operations when fire is present.

## Hydraulic System

The hydraulic system of a crashed aircraft should be considered a potential hazard. The loss of hydraulic fluid/pressure could cause an unexpected movement of the aircraft. The landing gear could collapse or brakes could release, causing injury to personnel.

## FLUID LINE IDENTIFICATION

Many different types of liquids and gases are required for the operation of aircraft. These liquids and gases are transmitted through many feet of tubing and flexible hose. Both liquids and gases are called fluids, and tubing and flexible hose are referred to as lines. The term "*fluid lines*" is used in the following discussion.

Each fluid line in an aircraft is identified by bands of paint or strips of tape around the line near each fitting. These identifying markers are applied at least

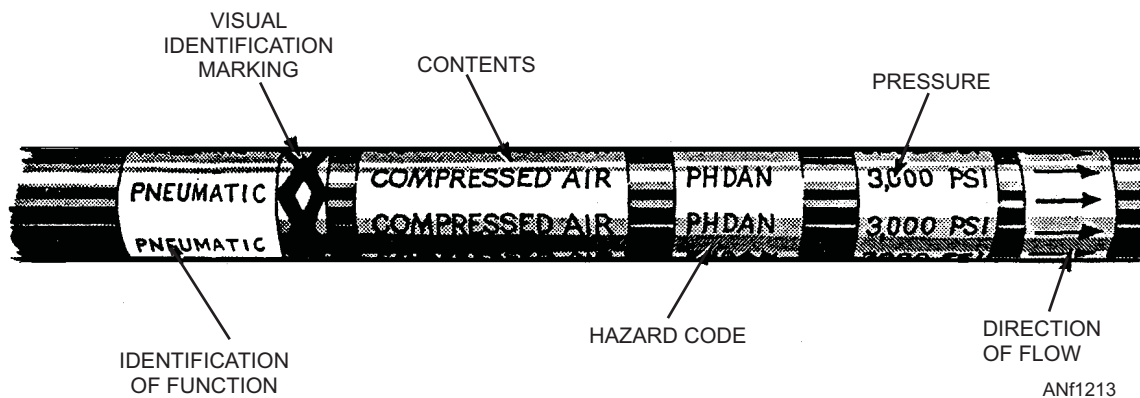

Figure 12-13.—Fluid line identification application.

once in each compartment. Various other information is also applied to the lines.

In most instances, lines are marked by the use of tape or decals. On lines 4 inches and larger in diameter, steel tags may be used in place of tape or decals. On lines in engine compartments, where there is a possibility of tapes, decals, or tags being drawn into the engine intake, paint is usually used.

Identification tape codes indicate the function, contents, hazards, direction of flow, and pressure in the fluid line. These tapes are applied according to MIL-STD-1247. This Military Standard was issued to standardize fluid line identification throughout the Department of Defense. Figure 12-13 shows the application of these tapes as specified by this standard.

The function of a line is identified by the use of a tape. The tape is approximately 1-inch wide, where

words, colors, and geometric symbols are printed. Functional identification markings, as shown in MIL-STD-1247, are the subject of international standardization agreement. The function of the line is printed in English across the colored portion of the tape. Three-fourths of the total width on the left side of the tape has a code color. Non-English-speaking people can troubleshoot or maintain the aircraft if they know the color code.

The right-hand, one-fourth of the functional identification tape contains a geometric symbol that is different for every function. This symbol ensures that all technicians, whether colorblind or non-English-speaking will be able to identify the line function. Figure 12-14 is a listing of functions and their associated colors and identification markings as used on tapes.

FUNCTION	COLOR	SYMBOL
FUEL	RED	◆
ROCKET OXIDIZER	GREEN, GRAY	☾
ROCKET FUEL	RED, GRAY	◆☾
WATER INJECTION	RED, GRAY, RED	∇
LUBRICATION	YELLOW	⋮
HYDRAULIC	BLUE, YELLOW	●
SOLVENT	BLUE, BROWN	≡
PNEUMATIC	ORANGE, BLUE	∞
INSTRUMENT AIR	ORANGE, GRAY	⚡
COOLANT	BLUE	∞
BREATHING OXYGEN	GREEN	■
AIR CONDITIONING	BROWN, GRAY	⋯
MONOPROPELLANT	YELLOW, ORANGE	⊥
FIRE PROTECTION	BROWN	◆
DE-ICING	GRAY	▲
ROCKET CATALYST	YELLOW, GREEN	≡
COMPRESSED GAS	ORANGE	↘
ELECTRICAL CONDUIT	BROWN, ORANGE	⚡
INERTING	ORANGE, GREEN	++

ANf1214

Figure 12-14.—Functional identification tape data.

The identification of hazard tape shows the hazard associated with the contents of the line. Tapes used to show hazards are approximately 1/2-inch wide, with the abbreviation of the hazard associated with the fluid in the line printed across the tape. There are four general classes of hazards found in connection with fluid lines.

- Flammable material (FLAM). The hazard marking FLAM is used to identify all materials known as flammables or combustibles.
- Toxic and poisonous materials (TOXIC). A line identified by the word TOXIC contains materials that are extremely hazardous to life or health.
- Anesthetics and harmful materials (AAHM). All materials that produce anesthetic vapors and all liquid chemicals and compounds that are hazardous to life and property.
- Physically dangerous materials (PHDAN). A line that carries material that is asphyxiating in confined areas or is under a dangerous physical state of pressure or temperature. For example, the line shown in figure 12-13 is marked PHDAN because the compressed air is under a pressure of 3,000 psi.

**Table 12-1.—Hazards Associated With Various Fluids and Gases**

CONTENT	HAZARD
Air (under pressure)	PHDAN
Alcohol	FLAM
Carbon dioxide	PHDAN
Freon	PHDAN
Gaseous oxygen	PHDAN
Liquid nitrogen	PHDAN
Liquid oxygen	PHDAN
LPG (liquid petroleum gas)	FLAM
Nitrogen gas	PHDAN
Oils and greases	FLAM
JP-5	FLAM
Trichloroethylene	AAHM

*Q12-13. What aviation jet fuel is prohibited for use aboard ship due to its "flash point"?*

*Q12-14. What is the preferred fire-fighting agent used to cool an overheated battery in the absence of flame or fire?*

*Q12-15. What is the purpose of functional identification tape?*

## AIRCRAFT FIRE-FIGHTING TACTICS

**LEARNING OBJECTIVE:** Recognize the various fire-fighting techniques based upon the existing emergency conditions.

Aircraft fire-fighting, crash, and rescue techniques are well defined, but no two fire situations will be identical. Success will continue to depend on training, planning, leadership, and teamwork by both ship's company and air wing personnel. Supervisory personnel, fire parties, and squadron personnel should take advantage of every opportunity to drill and acquire knowledge of fixed and mobile fire-fighting equipment available to them. All personnel should become familiar with aircraft configuration, fuel load, weapons load, and fire-fighting techniques of assigned aircraft. The following text discusses procedures recommended for training purposes.

## ACCESSORY SECTION, COMPRESSOR COMPARTMENT, OR ENGINE COMPARTMENT OF JET FIXED-WING AND ROTARY-WING AIRCRAFT

### CAUTION

When AFFF is used as the fire suppression agent on an aircraft fire and the agent is directed at or ingested into the engine or accessory sections, the fire chief or senior fire official must notify the maintenance officer of the unit involved or, in the case of a transient aircraft, the supporting facility.

Fires in the accessory section, compressor compartment, or engine compartment of jet aircraft result from fuel being introduced into the area between the engine and fuselage, or between the engine and nacelle on engines carried in pods that come into contact with the heat generated by the engine. You must be familiar with these areas to be able to properly apply extinguishing agents. (For more information, refer to NATOPS, *U.S. Navy Aircraft Emergency Rescue Information Manual*, NAVAIR 00-80R-14-1.)

Halon 1211 or CO<sub>2</sub> are the extinguishing agents used on these fires. However, when a fire in an aircraft cannot be extinguished with Halon 1211 or CO<sub>2</sub>, the use of AFFF to prevent further damage outweighs the disadvantages.

### Internal Engine Fires

Internal engine fires usually result when residual fuel is dumped into the engine on shutdown. When starting equipment and qualified starting personnel are immediately available, these fires may be controlled by windmilling the engine. If this procedure fails or if the equipment and personnel are not available, an extinguishing agent must be directed into the engine. Halon 1211 or CO<sub>2</sub> is the primary agent for internal fires. Application of Halon 1211 or CO<sub>2</sub> must be accomplished at a distance so that the Halon 1211 or CO<sub>2</sub> enters the fire area in gaseous form.

#### CAUTION

When CO<sub>2</sub> or Halon 1211 is expelled directly into an engine, thermal shock may result, causing engine damage. High bypass turbofan engines require unique techniques to extinguish engine core fires.

### Aircraft Engine Fires

Use the following procedures for extinguishing fires in high bypass turbofan engines:

1. Engine accessory section fire.
  - a. Halon 1211 or CO<sub>2</sub> may be introduced into the engine accessory section area through the access doors located on the aircraft engine cowling.
  - b. When the fire is under control, one fire fighter in full protective clothing (hot suit) will open the engine cowling. An AFFF hand line should be used to provide fire protection to the fire fighter.

**NOTE:** A screwdriver may be required to open the engine cowling due to the restrictions of proximity gloves.

2. Engine fire turbine section engine core. When the engine is shutdown, apply Halon 1211 or CO<sub>2</sub>, and if required AFFF, into the aircraft exhaust section only until the fire is extinguished.
3. Engine fire in compressor section engine core.

#### CAUTION

The source of this fire will probably be burning titanium, and can be identified by the sparking effect of this material when it is burning. This fire is potentially destructive and may possibly burn through the engine casing if immediate fire suppression measures are not taken.

- a. Halon 1211 or CO<sub>2</sub> may be introduced into the engine intake, exhaust, or accessory section.
- b. When the fire is under control, one fire fighter in full protective clothing (hot suit) will open the engine cowling. An AFFF hand line should be used to provide fire protection to the fire fighter.
- c. When the engine cowling is open, apply AFFF to both sides of the engine casing to complete extinguishing and provide additional cooling.

### Electrical and Electronic Equipment Fires

In combating electrical fires, you must secure the source of electrical power. For combating class C fires, Halon 1211 or CO<sub>2</sub> is the primary agent, and should have no adverse effect on electrical or electronic components.

#### WARNING

Halon 1211 may be used in a small electronics compartment to make the atmosphere inert, provided fire fighters do not enter the compartment, or enter it with a self-contained breathing apparatus. Do NOT use CO<sub>2</sub> to make the atmosphere in an electronics compartment inert, as it may produce a spark.

### TAILPIPE FIRES

When a fire occurs in the tailpipe of an aircraft during shutdown, the aircraft engine should be started by authorized personnel in order to attempt extinguishing through exhaust pressures. If this operation does not extinguish the fire, the following should be performed by the crash crew.

1. Direct fire-extinguishing agents Halon 1211 or CO<sub>2</sub> into the tailpipe.
2. If fire is not extinguished by the above methods, direct the stream of extinguisher agent into the intake duct.

### WARNING

Do not stand directly in front of the intake duct.

## HOT BRAKES

During a normal or an emergency landing, the landing gear is an item of considerable concern. With the added weight and landing speeds of modern aircraft, and because of the extreme braking required on shorter runways, overheated brakes and wheels are a common occurrence. You, as a fire fighter, must have a thorough understanding of the hazards created by overheated brakes, as well as the techniques and equipment used with this type of emergency.

Overheated aircraft wheels and tires present a potential explosion hazard because of built-up air pressure in the tires, which is greatly increased when fire is present. To avoid endangering the crews needlessly, all nonessential personnel should evacuate the area. The recommended procedure for cooling overheated wheel, brake, and tire assemblies is to park the aircraft in an isolated area and allow the assemblies to cool in the surrounding air. Using cooling agents, such as water, is not recommended unless absolutely necessary due to increased hazards to personnel near the overheated assembly. Most aircraft operating manuals for propeller-driven aircraft recommend that flight crews keep the propeller turning fast enough to provide an ample cooling airflow. Most major jet, propeller-driven, and turboprop aircraft now have fusible plugs incorporated in the wheel rims. These fusible plugs are designed to automatically deflate the tires. (Failure of fusible plugs to function properly has occurred.) Releasing the tire pressure reduces the pressure on the wheel, and thus eliminates the possibility of explosion.

### CAUTION

The use of CO<sub>2</sub> for rapid cooling of a hot brake or wheel assembly is extremely dangerous. Explosive fracture may result because of the rapid change in temperature.

When responding to a wheel fire or hot brakes as a member of the emergency crew, you should approach the wheel with extreme caution in a fore or aft direction, never from the side in line with the axle. Peak temperatures may not be reached until 15 to 20 minutes

after the aircraft has come to a complete stop. See figure 12-15.

## WHEEL ASSEMBLY FIRES

The following types of fires and hazards may occur around an aircraft wheel assembly:

1. The heating of aircraft wheels and tires presents a potential explosion hazard, which is greatly increased when fire is present. The combination of increased stress on the brake wheel assembly, additional tire pressure, and the deterioration of components by heat may cause an explosion. This explosion is likely to propel pieces of the tire and/or metal through the air at high speeds.

2. Materials that may contribute to wheel assembly fires are grease, hydraulic fluid, bearing lubricants, and tire rubber.

a. Grease and bearing lubricant fires. When ignited, wheel grease fires can be identified by long flames around the wheel brake/axle assembly. These fires are usually small and should be extinguished quickly with Halon 1211 or water fog.

b. Rubber tires. Rubber from the tires may ignite at temperatures from 500°F (260°C) to 600°F (315°C) and can develop into an extremely hot and destructive fire. Halon 1211 or water fog should be used as early as possible to extinguish the fire. Reignition may occur if the rubber sustains its autoignition temperature or if the rubber is abraded and the fire is deep-seated.

c. A broken hydraulic line may result in the misting of petroleum-based fluids onto a damaged or

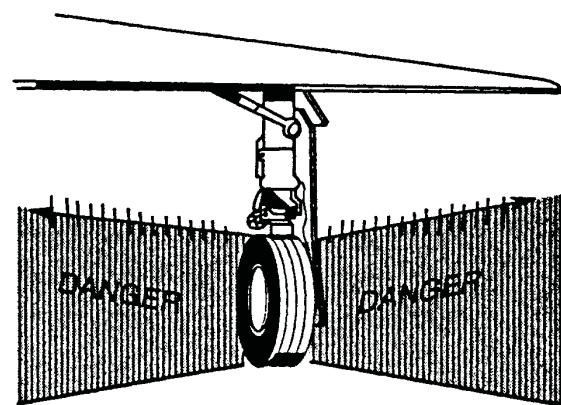

ANf1215

Figure 12-15.—Danger zones and attack zones in combating wheel fires. (Attack the fire from fore and aft—do not attack from the side).

hot wheel assembly. Upon ignition, misting fluid will accelerate a fire, resulting in rapid fire growth and excessive damage to the aircraft if it is not extinguished rapidly.

### **WARNING**

A broken hydraulic line that causes misting of petroleum-based fluids around an overheated brake assembly can cause a potentially dangerous and destructive fire. Intermittent application of water fog should be used to extinguish this type of wheel assembly fire. Rapid cooling of a hot inflated aircraft tire/wheel assembly presents an explosion hazard. Therefore, fire-fighting personnel must exercise good judgment and care to prevent injuries. The vaporized products of hydraulic fluid decomposition will cause severe irritation to the eyes and respiratory tract.

The following safety information pertains to all aspects of wheel assembly fire-fighting operations:

- Rapid cooling may cause an explosive failure of a wheel assembly.
- When water fog is used on a wheel assembly fire, an intermittent application of short bursts (5 to 10 seconds) every 30 seconds should be used.
- The effectiveness of Halon 1211 may be severely reduced under extremely windy conditions if the Halon cannot be maintained on the fire source.
- You must take protective measures to prevent hydraulic fluid from coming into contact with the eyes. Seek medical attention immediately should the fluid come in contact with the eyes.

- Positive-pressure, self-contained breathing apparatus must be worn in fighting fires associated with hydraulic systems.
- Although Halon 1211 may extinguish hydraulic fluid fires, reignition may occur because this agent lacks an adequate cooling effect.
- In a fire, F-14, S-3, and C-5 aircraft with beryllium brakes may produce irritating or poisonous gases. These gases are toxic, and they are respiratory and eye irritants.
- Because heat is transferred from the brake to the wheel, agent application should be concentrated on the brake area. The primary objective is to prevent the fire from spreading upward into wheel wells, wing, and fuselage areas.

*Q12-16. Where should you direct the fire-fighting agent for an internal engine fire?*

*Q12-17. What is the primary agent used to combat class C electrical fires?*

*Q12-18. What is the greatest hazard associated with overheated aircraft wheels and tires?*

*Q12-19. In what direction should you approach an aircraft with overheated brakes or a wheel fire?*

*Q12-20. What are the four materials that usually contribute to wheel assembly fires?*

### **SUMMARY**

In this chapter, you have learned about aircraft crash, rescue, and fire-fighting techniques and procedures. Fire chemistry, fire-fighting agents, and equipment used in dealing with naval aircraft were also covered.

(THIS PAGE IS INTENTIONALLY LEFT BLANK.)

# ASSIGNMENT 12

Textbook Assignment: "Crash Rescue and Fire Fighting," chapter 12, pages 12-1 through 12-21.

---

- 12-1. What is the primary duty of a fire fighter?
1. To prevent fire from spreading
  2. To save lives
  3. To extinguish fire
  4. To protect Navy equipment
- 12-2. There are four elements in the process of fire. The fourth element is a chemical reaction that allows the fire to sustain itself and grow. Which of the following terms describes this process?
1. Fire triangle
  2. Fire cube
  3. Fire tetrahedron
  4. Fire matrix
- 12-3. What is the term used to describe the lowest temperature at which vapors of a substance can be ignited and continue to burn?
1. Fire point
  2. Flash point
  3. Ignition point
  4. Spark point
- 12-4. What is the term used to describe the temperature at which a substance gives off enough vapors to form an ignitable mixture in the air near its surface?
1. Fire point
  2. Flash point
  3. Ignition point
  4. Spark point
- 12-5. At what exposed temperatures will a portion of fuel (or its vapors) spontaneously ignite?
1. 200°F
  2. 300°F
  3. 400°F
  4. 500°F
- 12-6. What class of fires occur in combustible materials, such as bedding, mattresses, books, cloth, and any matter that produces an ash?
1. Class A
  2. Class B
  3. Class C
  4. Class D
- 12-7. What class of fires occur with flammable liquid substances, such as gasoline, jet fuels, paints, grease, and any petroleum-based products?
1. Class A
  2. Class B
  3. Class C
  4. Class D
- 12-8. What class of fires is associated with electrically energized equipment?
1. Class A
  2. Class B
  3. Class C
  4. Class D
- 12-9. What class of fires is associated with combustible metals, such as magnesium and titanium?
1. Class A
  2. Class B
  3. Class C
  4. Class D
- 12-10. Water is most efficient when it absorbs enough heat to raise its temperature to a boiling point, and then changes to steam that carries away the heat, which cools the surface temperature.
1. True
  2. False
- 12-11. When proportioned with water, AFFF provides which of the following fire-extinguishing advantages?
1. An aqueous film is formed on the surface of the fuel that prevents the escape of the fuel vapors
  2. The layer effectively excludes oxygen from the fuel surface
  3. The water content of the foam provides a cooling effect
  4. Each of the above

- 12-12. What is the primary fire-fighting agent used to extinguish burning flammable or combustible liquid spill fires?
1. Water
  2. AFFF
  3. PKP
  4. Halon
- 12-13. By what means does CO<sub>2</sub> extinguish a fire?
1. By cooling the fire below its ignition temperature
  2. By eliminating all heat
  3. By diluting and displacing its oxygen supply
  4. By settling and blanketing the fire
- 12-14. By what means does Halon 1211 extinguish a fire?
1. By cooling the fire below its ignition temperature
  2. By eliminating all heat
  3. By settling and blanketing the fire
  4. By inhibiting the chemical chain reaction and decomposing upon contact with flames
- 12-15. What two fire-fighting agents are used in the twin agent units on board flight and hangar deck mobile fire-fighting equipment?
1. AFFF/Halon 1211
  2. CO<sub>2</sub>/PKP
  3. Water/AFFF
  4. PKP/Halon 1211
- 12-16. What fire-fighting agent is used for combating flammable liquid fires?
1. Water fog
  2. AFFF
  3. PKP
  4. CO<sub>2</sub>
- 12-17. What is the diameter of fire hoses used on board naval ships?
1. 1/2 or 1 inch
  2. 1 1/2 or 2 1/2 inch
  3. 2 or 3 inch
  4. 2 1/2 or 3 1/2 inch
- 12-18. How many gallons of concentrated AFFF are contained in a high-capacity AFFF station on board ship?
1. 200 gallons
  2. 400 gallons
  3. 600 gallons
  4. 800 gallons
- 12-19. Where are the AFFF sprinkler systems installed in the hangar bay aboard ship?
1. In the overhead
  2. On the hangar deck
  3. On each bulkhead
  4. In each CONFLAG station
- 12-20. Where are the flight deck AFFF fixed fire-fighting system controls located?
1. Primary flight control (Pri-Fly)
  2. Navigation bridge
  3. Both 1 and 2 above
  4. Flight deck control
- 12-21. Vari-nozzles are used on all AFFF and saltwater hose lines. All nozzle gallon-per-minute flow rates are based on what psi pressure at the nozzle inlet?
1. 100 psi pressure
  2. 200 psi pressure
  3. 300 psi pressure
  4. 400 psi pressure
- 12-22. What is (a) the length of Navy fire hoses and (b) the maximum operating pressure?
1. (a) 20 feet (b) 100 psi
  2. (a) 35 feet (b) 225 psi
  3. (a) 50 feet (b) 270 psi
  4. (a) 75 feet (b) 340 psi
- 12-23. Fire hose pressure above 150 psi is hazardous because excessive nozzle reaction force may result in loss of nozzle control.
1. True
  2. False
- 12-24. What is the purpose of the hard-rubber and hardwood plugs contained in the aircraft tool kit?
1. To seal ruptured fire hoses
  2. To stop fuel tank leaks
  3. To seal off aircraft intakes
  4. To wedge open aircraft canopies
- 12-25. How does aluminized protective clothing provide protection to fire fighters?
1. Because of its thermal lining
  2. Because of a positive airflow valve that cools the wearer
  3. Due to its high percentage of reflectivity to radiant heat
  4. Because of its lightweight fabric construction and ease of mobility

- 12-26. How much heat protection is lost when the gold-coated facepiece on the aluminized proximity suit becomes worn, scratched, or marred?
1. 25 %
  2. 40 %
  3. 65 %
  4. 90 %
- 12-27. The Oshkosh T-3000 crash and fire-fighting truck has a water and AFFF capacity of what total number of gallons?
1. 1,000 gallons of water and 220 gallons of AFFF
  2. 2,000 gallons of water and 310 gallons of AFFF
  3. 3,000 gallons of water and 420 gallons of AFFF
  4. 4,000 gallons of water and 510 gallons of AFFF
- 12-28. Where is the water and AFFF mixed on the P-4A aircraft fire-fighting vehicle before discharge?
1. Mixed in venturi inductors
  2. It is premixed in the holding tank
  3. Mixed by the variable-stream roof turret
  4. Mixed by the AFFF concentrate centrifugal pumps
- 12-29. The P-4A aircraft fire-fighting vehicle comes equipped with what total number of 30-pound PKP dry-chemical fire extinguishers?
1. Two
  2. Five
  3. Four
  4. Three
- 12-30. What fire extinguishing agents are carried on the P-19 fire-fighting truck?
1. PKP, water, and CO<sub>2</sub>
  2. Water, foam, and Halon 1211
  3. Halon 1211, PKP, and water
  4. CO<sub>2</sub>, Halon 1211, and foam
- 12-31. Which of the following aircraft fire-fighting vehicles are used aboard ship?
1. P-4A
  2. P-19
  3. P-25
  4. T-3000
- 12-32. How are the brakes engaged on the P-25 shipboard fire-fighting vehicle?
1. Depress the clutch pedal
  2. Release the accelerator
  3. Apply the hydraulic cylinder lever
  4. Disengage the transmission
- 12-33. The twinned agent unit (TAU-2H) is primarily designed for extinguishing what class of fires?
1. Class A
  2. Class B
  3. Class C
  4. Class D
- 12-34. The Halon nozzle on the twinned agent unit (TAU-2H) is equipped with what type of tip?
1. High-velocity tip
  2. Aspirating tip
  3. Dual orifice tip
  4. Low-reaction discharge tip
- 12-35. For what reason is JP-4 jet fuel prohibited aboard Navy ships?
1. Because of its flash point
  2. It cannot be mixed with other fuels
  3. It contaminates the ships fuel systems
  4. A fuel fire is difficult to extinguish
- 12-36. What is the calculated rate of flame spread for aviation gasoline (AVGAS) and JP-4 jet fuel?
1. 100 to 300 feet per minute
  2. 200 to 400 feet per minute
  3. 700 to 800 feet per minute
  4. 500 to 900 feet per minute
- 12-37. What is the lowest flash point of aircraft fuels that is considered safe for use aboard naval vessels?
1. 80°F
  2. 110°F
  3. 120°F
  4. 140°F
- 12-38. The top portion of the fuel tank is more void of liquid than any other section of the tank. In the event of an explosion, the liquid itself provides a restraining cushion, which will direct the explosive force in what direction?
1. Upward
  2. Downward
  3. Horizontally
  4. Diagonally

- 12-39. What color is liquid oxygen in an aircraft oxygen system?
1. White
  2. Light blue
  3. Yellow
  4. Light green
- 12-40. At what temperature does liquid oxygen turn or boil into gaseous oxygen?
1. 212°F
  2. -32°F
  3. -297°F
  4. 121°F
- 12-41. What is the usual mixture of aircraft anti-icing fluids?
1. 90% alcohol and 10% glycerin
  2. 75% alcohol and 25% glycerin
  3. 45% alcohol and 55% glycerin
  4. 85% alcohol and 15% glycerin
- 12-42. What fire-extinguishing agent should be applied to extinguish an ignited Mk 45 or LLU-2 parachute flare?
1. Halon 1211
  2. AFFF
  3. Low-velocity fog
  4. PKP
- 12-43. What fire extinguishing agent should NOT be directed into a battery compartment to effect cooling or to displace explosive gases because of the risk of explosion?
1. CO<sub>2</sub>
  2. AFFF
  3. Water fog
  4. PKP
- 12-44. What fire-extinguishing agent is used to lower the temperature of an aircraft battery that is in a thermal runaway condition when no flame or fire is present?
1. CO<sub>2</sub>
  2. AFFF
  3. Water fog
  4. PKP
- 12-45. Because of the potential hazards to personnel, what additional protection is necessary for personnel to combat composite fibers resulting from an aircraft fire?
1. More fire party personnel
  2. Respiratory protection
  3. Additional proximity suit liner
  4. Special eyewear
- 12-46. What advantage(s) does composite materials reinforced with carbon/graphite fibers provide in advanced aircraft construction?
1. Superior stiffness
  2. High strength-to-weight ratio
  3. Ease of fabrication
  4. All of the above
- 12-47. In composite aircraft construction, boron fibers pose less of a problem to unprotected electrical equipment than carbon or graphite fibers.
1. True
  2. False
- 12-48. What area of an aircraft is the most common source of aircraft crash fires?
1. Engine compartment
  2. Landing gear
  3. Wing fuel tanks
  4. Ordnance/stores
- 12-49. How are aircraft fluid lines identified?
1. By the diameter and length of the line
  2. By the material it is made of
  3. By etched markings in the center
  4. By bands of paint or strips of tape around the line
- 12-50. On aircraft fluid lines, steel tags can be used in place of identification tape or decals on lines of what diameter?
1. 1 inch
  2. 2 inches
  3. 3 inches
  4. 4 inches or larger
- 12-51. What do identification tape codes indicate on aircraft fluid lines?
1. Function and contents
  2. Hazards and direction of flow
  3. Pressure in the fluid line
  4. All of the above
- 12-52. How many general classes of hazards are found in connection with fluid lines?
1. One
  2. Two
  3. Three
  4. Four

- 12-53. What does the hazard code PHDAN indicate on aircraft lines?
1. Potential electrical danger
  2. Physically dangerous material
  3. Anesthetics and harmful materials
  4. Toxic and poisonous materials

IN ANSWERING QUESTIONS 12-54 AND 12-55, REFER TO TABLE 12-1 IN THE TEXT.

- 12-54. What is the associated hazard code that identifies alcohol?
1. FLAM
  2. AAHM
  3. PHDAN
  4. TOXIC

- 12-55. What is the associated hazard code that identifies trichloroethylene?
1. FLAM
  2. AAHM
  3. PHDAN
  4. TOXIC

- 12-56. The success of aircraft fire-fighting, crash, and rescue techniques will continue to depend on which of the following factors?
1. Training
  2. Leadership
  3. Teamwork
  4. Each of the above

- 12-57. What person must be informed when AFFF is used as the fire suppression agent on an aircraft fire and the agent is directed at or ingested into the engine or accessory section?
1. The commanding officer
  2. The senior fire official on board ship
  3. The maintenance officer of the unit involved
  4. The squadron quality assurance officer

- 12-58. In addition to the use of fire-extinguishing agents, what other method may be used to control internal aircraft engine fires?
1. Installing the engine intake covers
  2. Windmilling the engine
  3. Turn the aircraft into the wind
  4. Let the fire burn itself out

- 12-59. When CO<sub>2</sub> or Halon 1211 is expelled directly into an engine that is hot or has an internal fire, which of the following conditions could occur?
1. Thermal shock
  2. An explosion
  3. Produce toxic fumes
  4. Thermal runaway

- 12-60. In what area would you introduce fire-extinguishing agents to put out a fire in the engine accessory section area?
1. Access doors on the engine cowling
  2. The engine intake
  3. The engine exhaust section
  4. The compressor section

- 12-61. How can burning titanium be identified?
1. By the color of the smoke
  2. By the smell produced
  3. By the sparking effect of the material
  4. By the large amount of ashes produced

- 12-62. When combating class C electrical fires, what is the first thing you should do?
1. Charge all fire hoses to maximum pressure
  2. Secure the source of electrical power
  3. Post a fire security watch
  4. Ensure a nonconductive rubber mat is placed on the deck for personnel protection

- 12-63. CO<sub>2</sub> should NOT be used to make the atmosphere in an electronics compartment inert for which of the following reasons?
1. The possibility of suffocation
  2. It may cause damage to the electrical components
  3. It may produce a spark

- 12-64. When a fire occurs in the tailpipe of an aircraft during shutdown, the aircraft engine should be started in order to attempt extinguishing through exhaust pressures.
1. True
  2. False

- 12-65. What is the recommended procedure for cooling overheated wheel, brake, and tire assemblies?
1. Direct a steady stream of water at the assemblies
  2. Apply water fog to cool the brakes
  3. Discharge short burst of CO<sub>2</sub> at the assemblies
  4. Allow assemblies to cool in the surrounding air
- 12-66. What is the purpose of fusible plugs incorporated in aircraft wheel rim assemblies?
1. Automatically deflates the tire
  2. Reduces the pressure on the wheel
  3. Eliminates the possibility of explosion
  4. All of the above
- 12-67. When responding to a wheel fire or hot brakes, in what direction should personnel approach the wheel assembly?
1. In a fore or aft direction of the wheel
  2. Side to side in line with the axle
  3. Diagonally with the landing gear
  4. Any direction is approved to fight the fire
- 12-68. Which of the following materials may contribute to wheel assembly fires?
1. Grease
  2. Tire rubber
  3. Hydraulic fluid
  4. Each of the above
- 12-69. At what temperatures may aircraft tires ignite?
1. 200°F to 400°F
  2. 500°F to 600°F
  3. 700°F to 800°F
  4. 900°F to 1000°F
- 12-70. What is the danger in combating wheel assembly fires on aircraft with beryllium brakes installed?
1. They may produce irritating or poisonous gases
  2. They burn out of control
  3. The brake temperature cannot be measured
  4. The heat is not transferred to the wheel